

# CONCRETE MEDIAN BARRIER WITH LIGHT STANDARDS

COUNTY OF	ITEM NO.	SHEET NO.
FAYETTE	7-113.01	T18

**NOTES:**

AT THE LOCATIONS WHERE POLES ARE TO BE INSTALLED ON MEDIAN BARRIER THE CONTRACTOR SHALL INSTALL THEM AS INDICATED BY THIS SHEET. ALL MATERIALS, LABOR AND INCIDENTALS, WITH THE EXCEPTION OF THE 3" RACEWAY, SHALL BE INCIDENTAL TO THE BID ITEM "POLE BASE IN MEDIAN WALL".

THE CONTRACTOR SHALL BLOW AN APPROPRIATELY SIZED MOUSE THROUGH ALL CONDUITS WITH A PULL STRING ATTACHED TO VERIFY THAT ALL CONDUITS ARE CLEAR OF ANY OBSTRUCTIONS. CONTRACTOR SHALL TIE OFF STRING AT EACH CONDUIT END. ALL CONDUITS SHALL HAVE PIPE/TEST PLUGS INSTALLED IF THE CONDUIT IS NOT IN USE OR ARE SPARES.

**JUNCTION BOX NOTES:**

CONSTRUCT JUNCTION BOXES FROM 1/4" A36 STEEL PLATE AND THE JUNCTION BOX COVER FROM 1/8" A36 PLATE. HOT DIP GALVANIZE BOX AND COVER AFTER FABRICATION AND IN ACCORDANCE WITH ASTM A123 AND THE STANDARD SPECIFICATIONS.

FITTINGS SHALL BE UL LISTED AND CSA-CERTIFIED CONCRETE TIGHT ON THE OUTSIDE OF THE JUNCTION BOX CONDUIT CONNECTION. USE A SEALING LOCK NUT AND A RIGID PVC CONDUIT BUSHING ON THE INSIDE FOR ALL CONDUIT PENETRATIONS.

GROUNDING LUG SHALL BE INSTALLED ON THE BACK WALL OF THE JUNCTION BOX. THE LUG SHOULD BE CENTERED AND BE SIZED TO RECEIVE ALL THE WIRE SIZES THAT ARE INDICATED ON THE PLAN SHEET.

LIBERALLY COAT THE THREADS OF THE COVER FASTENERS WITH ANTI-SEIZE COMPOUND DURING CONSTRUCTION AND BEFORE FINAL CLOSURE.

PROTECT COVER OF JUNCTION BOX FROM DAMAGE/DISFIGUREMENT FROM MASONRY COATING APPLICATION AND OTHER SOURCES BY TAPING OR WRAPPING DURING CONSTRUCTION. REMOVE PROTECTION PRIOR TO FINAL ELECTRICAL INSPECTION AND REPAIR ANY DAMAGE OR DISFIGUREMENT TO THE SATISFACTION OF THE ENGINEER AND AT NO COST TO THE DEPARTMENT.

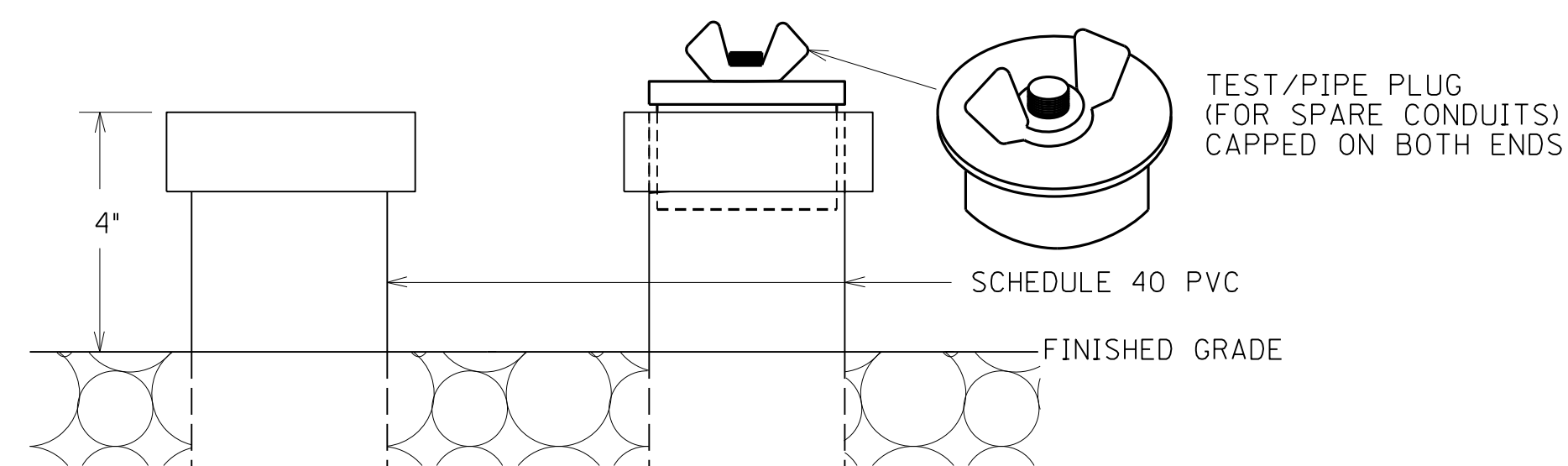
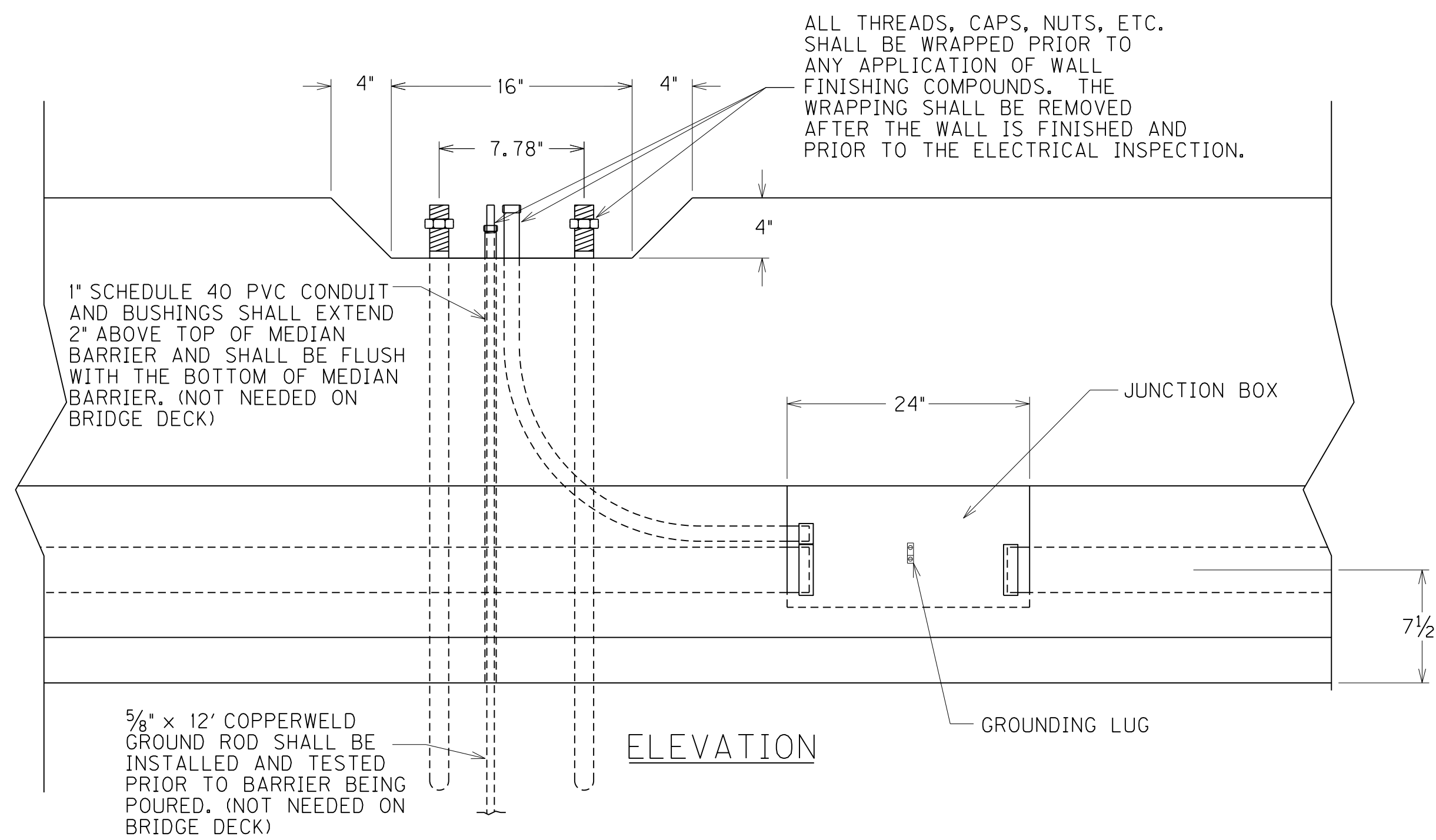
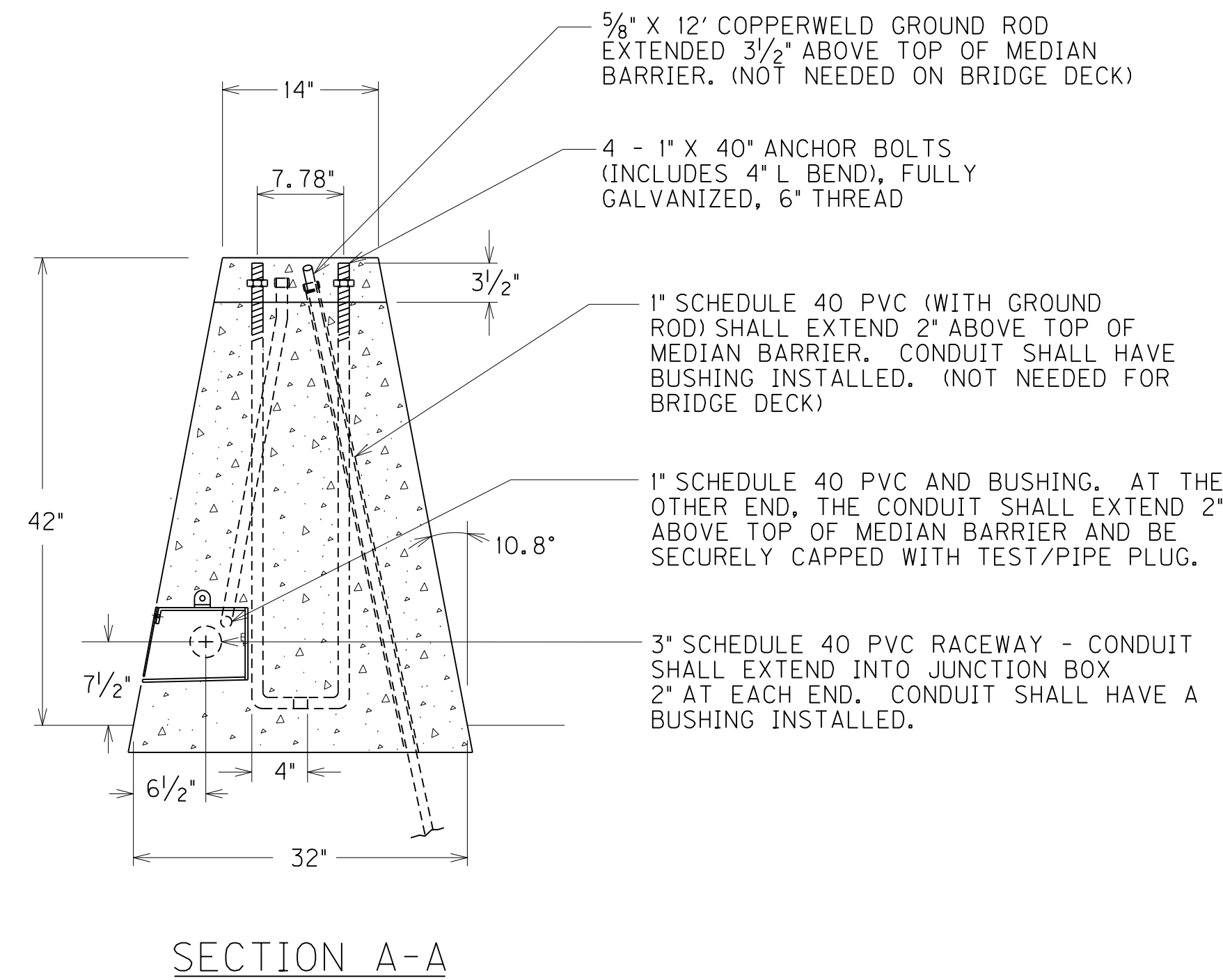
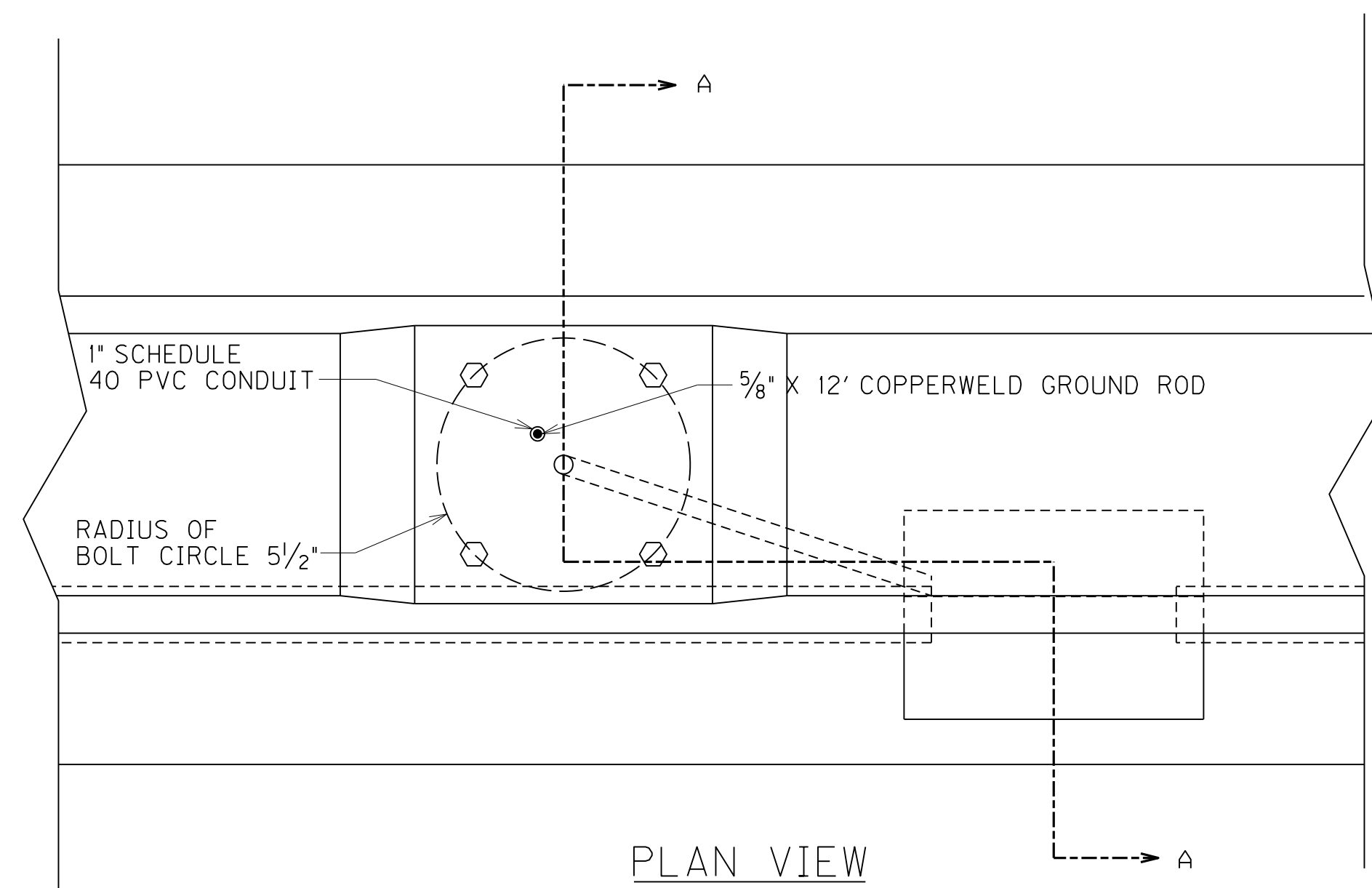

TEST/PIPE PLUG (FOR SPARE CONDUITS) DETAIL

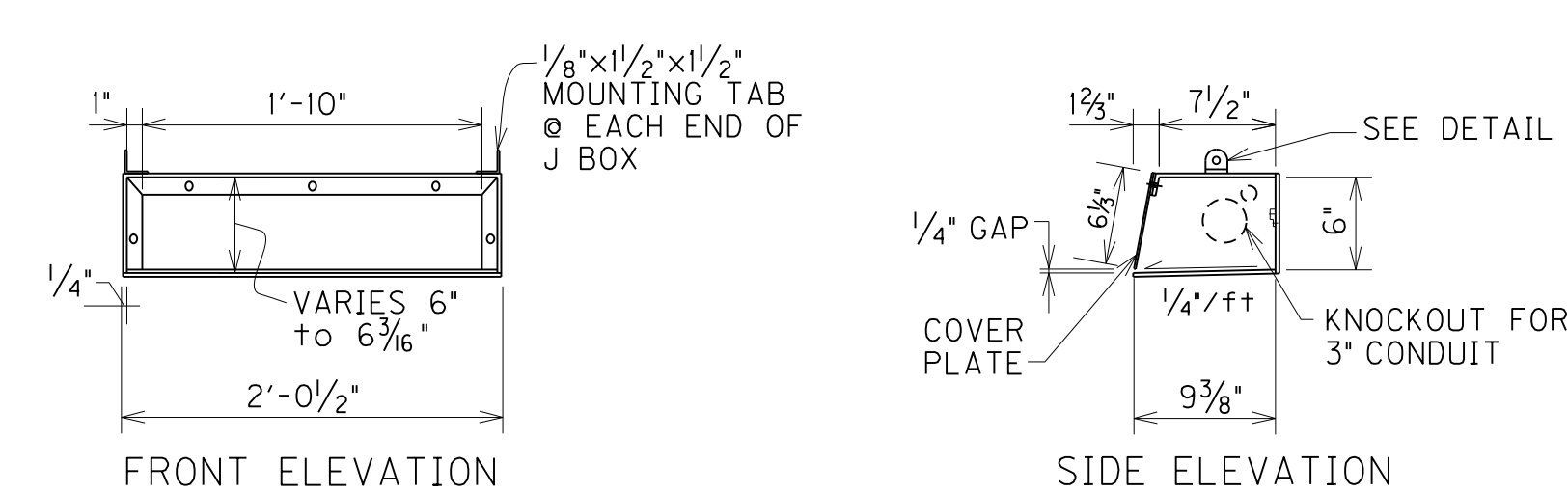
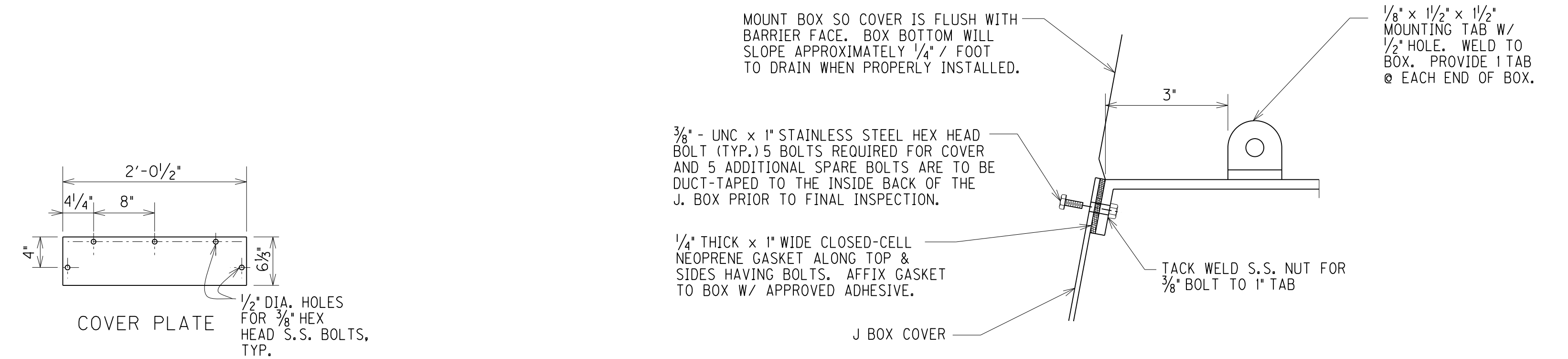

JUNCTION BOX

DETAIL

MEDIAN DETAILS

FILE NAME: C:\PWORK\TED.SWANSEGAR\MS28754\07\_08-BARRIER WALL (BW) NEW STRAIGHT.DGN

USER: ted.swansegar  
DATE PLOTTED: September 13, 2016

E-SHEET NAME: T018008W

MicroStation v8.11.7.443