

COUNTY OF	ITEM NO.	SHEET NO.

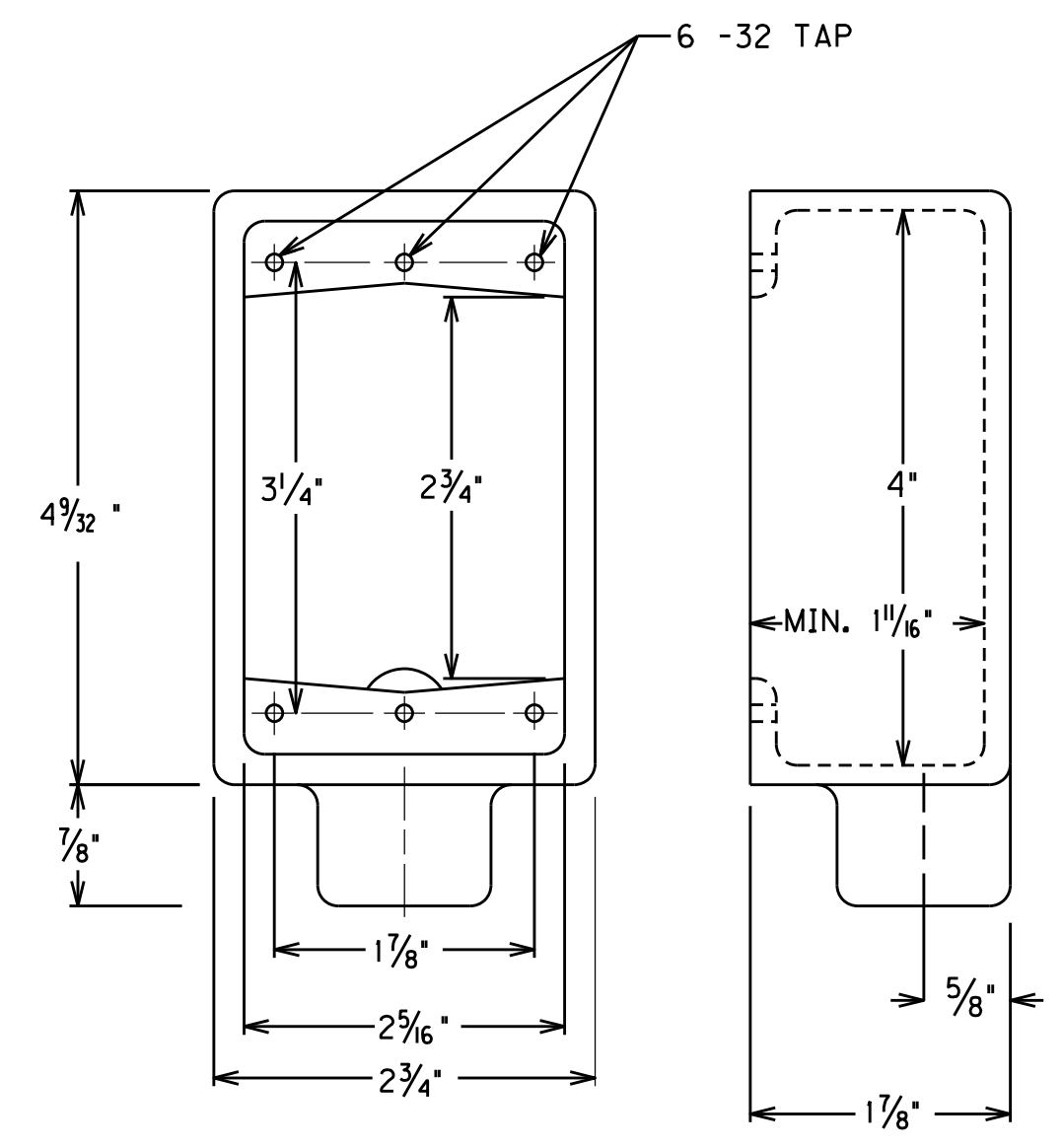

TYPE FS BOX FOR PED DETECTOR FOR USE WITH STEEL STRAIN POLE, WOOD POST, PEDESTAL, AND WOOD POLE

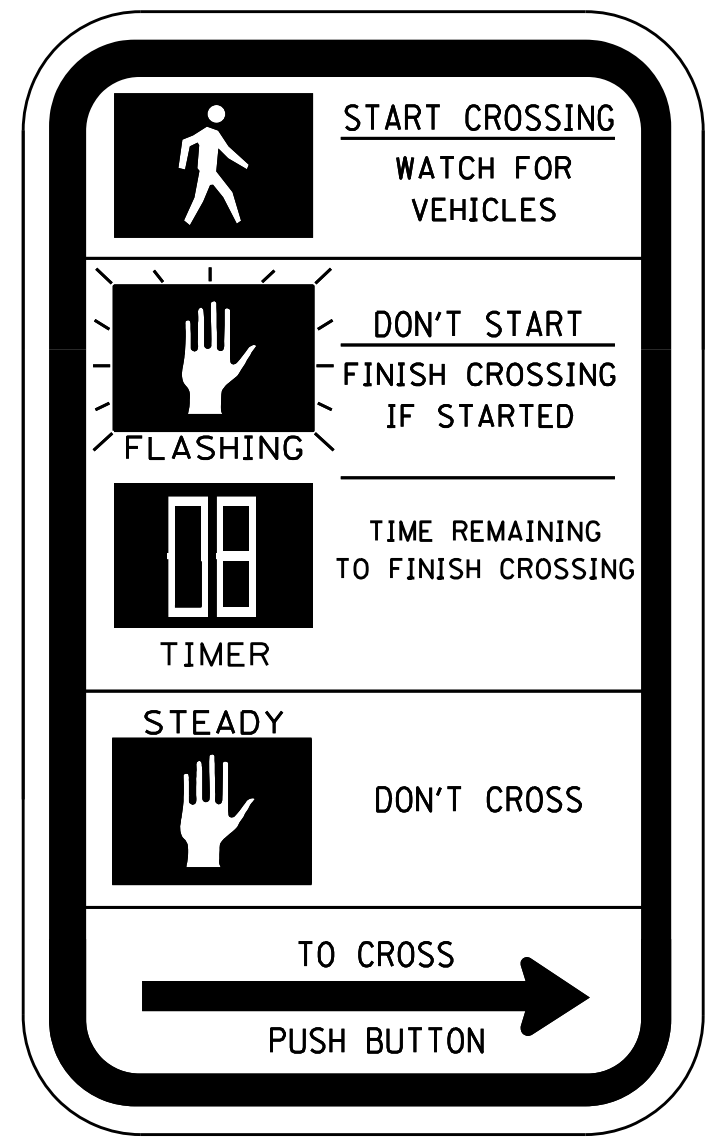

R10-3e SIGN (9" X 15") FOR COUNTDOWN ONLY

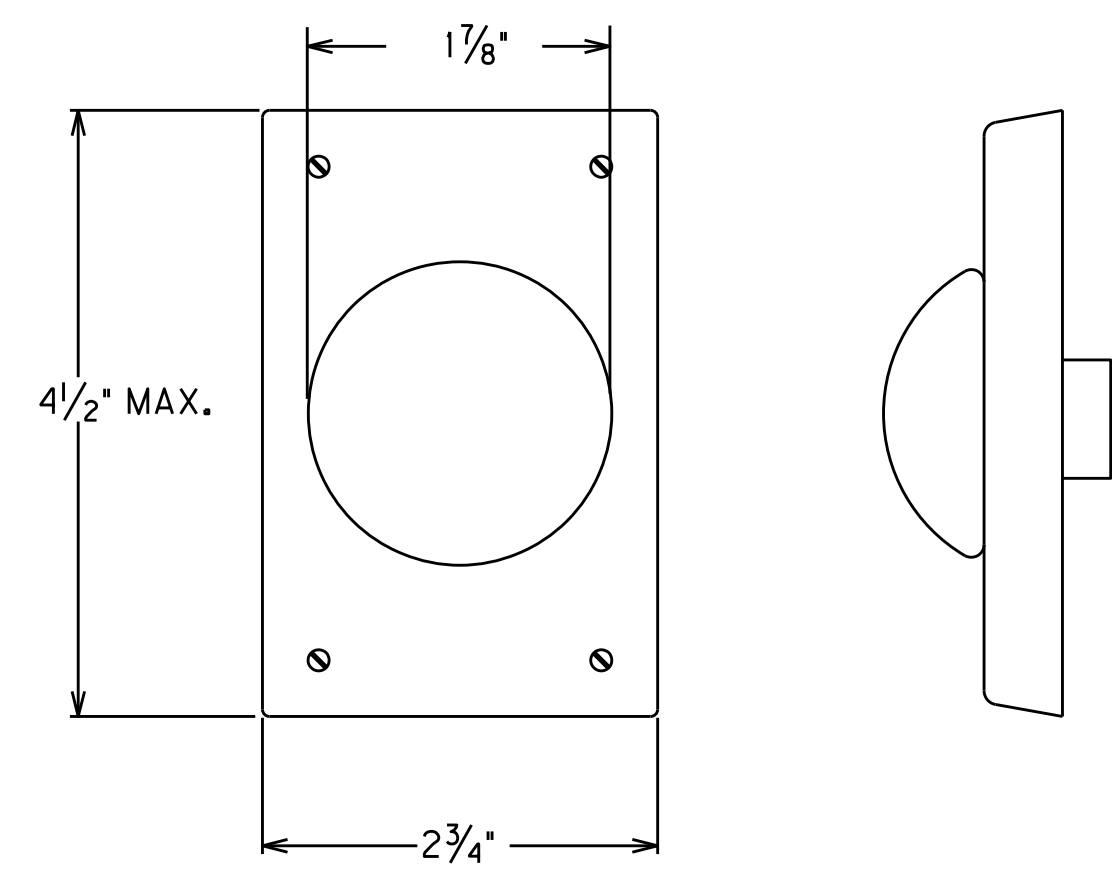

PED DETECTOR

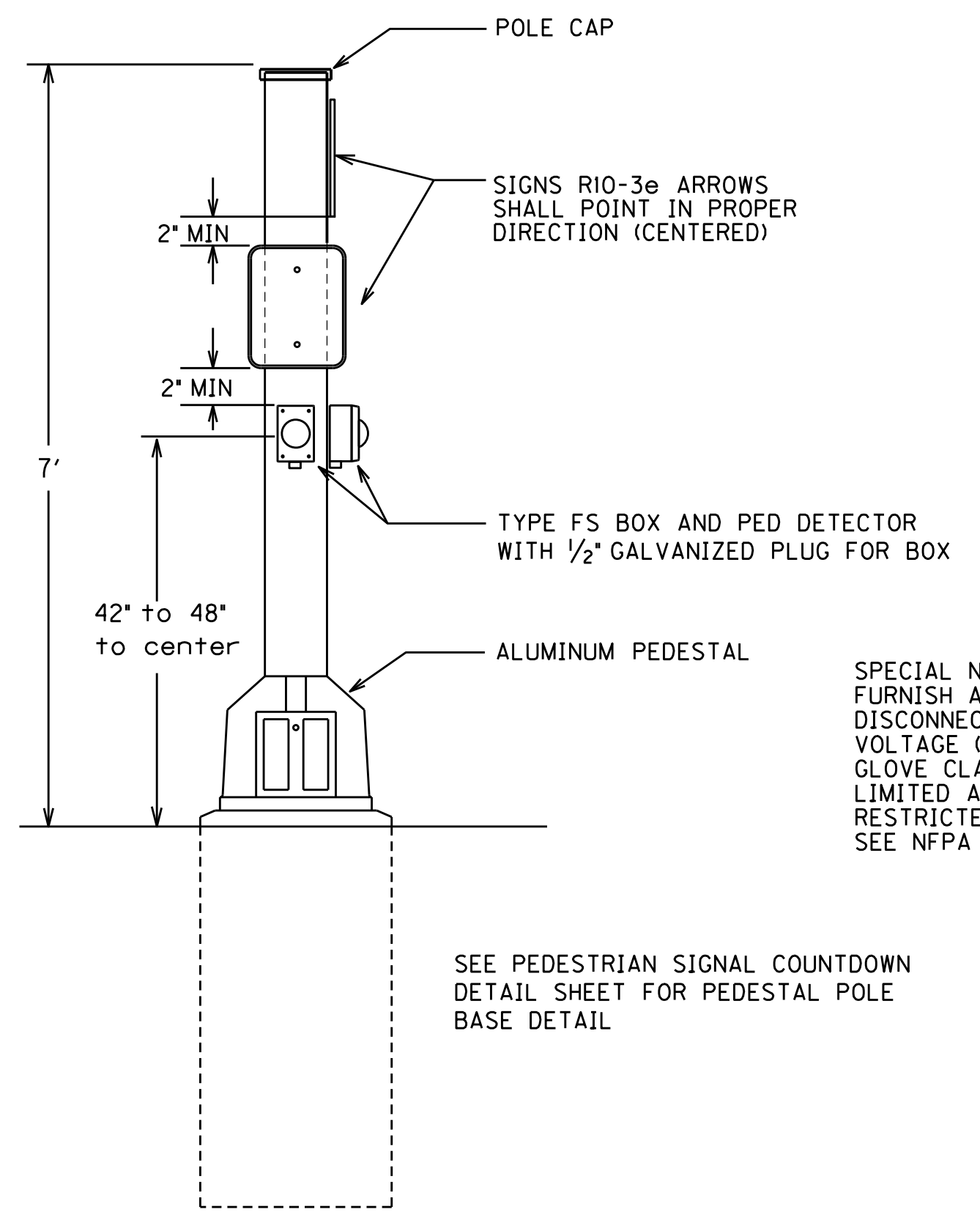

SPECIAL NOTE FOR TRANSFORMER DOOR: FURNISH A SHOCK HAZARD WARNING STICKER ON DISCONNECT WITH THE FOLLOWING INFORMATION: VOLTAGE (120 VOLT) GLOVE CLASS (0) LIMITED APPROACH BOUNDARY (42 IN) RESTRICTED APPROACH BOUNDARY (CONTACT) SEE NFPA 70E FOR ADDITIONAL PPE REQUIRED

SEE PEDESTRIAN SIGNAL COUNTDOWN DETAIL SHEET FOR PEDESTAL POLE BASE DETAIL

PEDESTAL POST DETAIL FOR PED DETECTORS & SIGNS

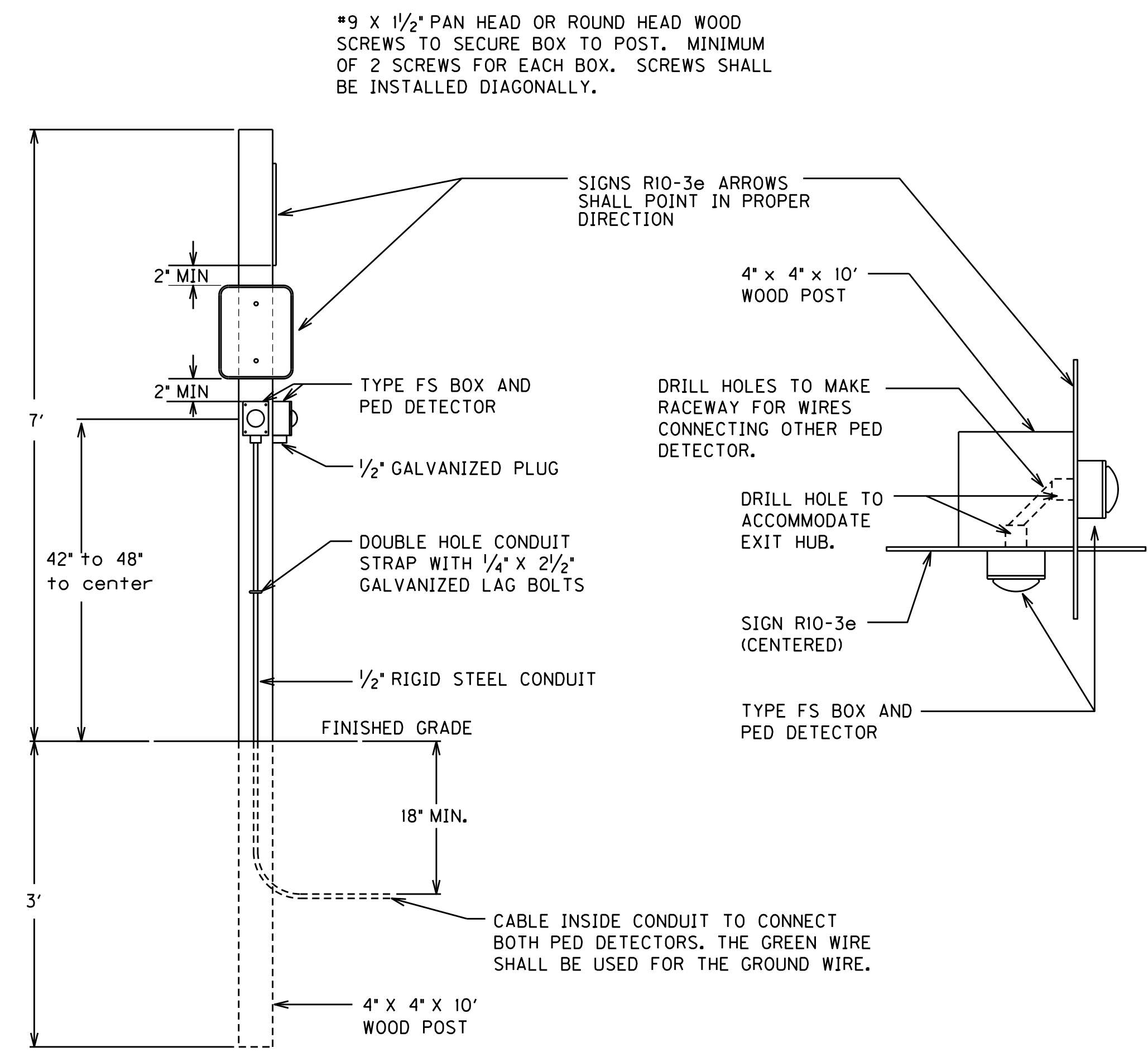

*9 X 1 1/2" PAN HEAD OR ROUND HEAD WOOD SCREWS TO SECURE BOX TO POST. MINIMUM OF 2 SCREWS FOR EACH BOX. SCREWS SHALL BE INSTALLED DIAGONALLY.

PED DETECTOR ON WOOD POST DETAIL

PEDESTRIAN DETECTOR DETAIL

FILE NAME: C:\P\WORK\TED.SWANSEGAR\MS28756\05-PED DETECTOR (P01).DGN
 USER: Ted.Swansegar
 DATE PLOTTED: October 18, 2022
 E-SHEET NAME:
 Power_InRoads v8.11.3.397